

STEERING SPECIFICATIONS			
WHEEL DIAMETER	46"	1220	MM
RIM FORCE	300 LBS.	136	KG
WHEEL/RUDDER TURN RATIO	10:1		
SPROCKET DIAMETER	32"	81	MM
CHAIN SIZE	1"	25	MM
CABLE DIAMETER	9/32"	7	MM
MIN. BR. STR.	7500 LBS.	3440	KG
SHEAVE DIAMETER	4"	102	MM
QUADRANT DIAMETER	45.0"	1163	MM
RUDDER TO TURN	±40°	MINIMUM	

NOTE: DO NOT BORE THRU RUDDER SHAFT.  
DO NOT CRUSH SHAFT WITH QUADRANT  
ATTACHMENT. CONSIDER KEYWAY.

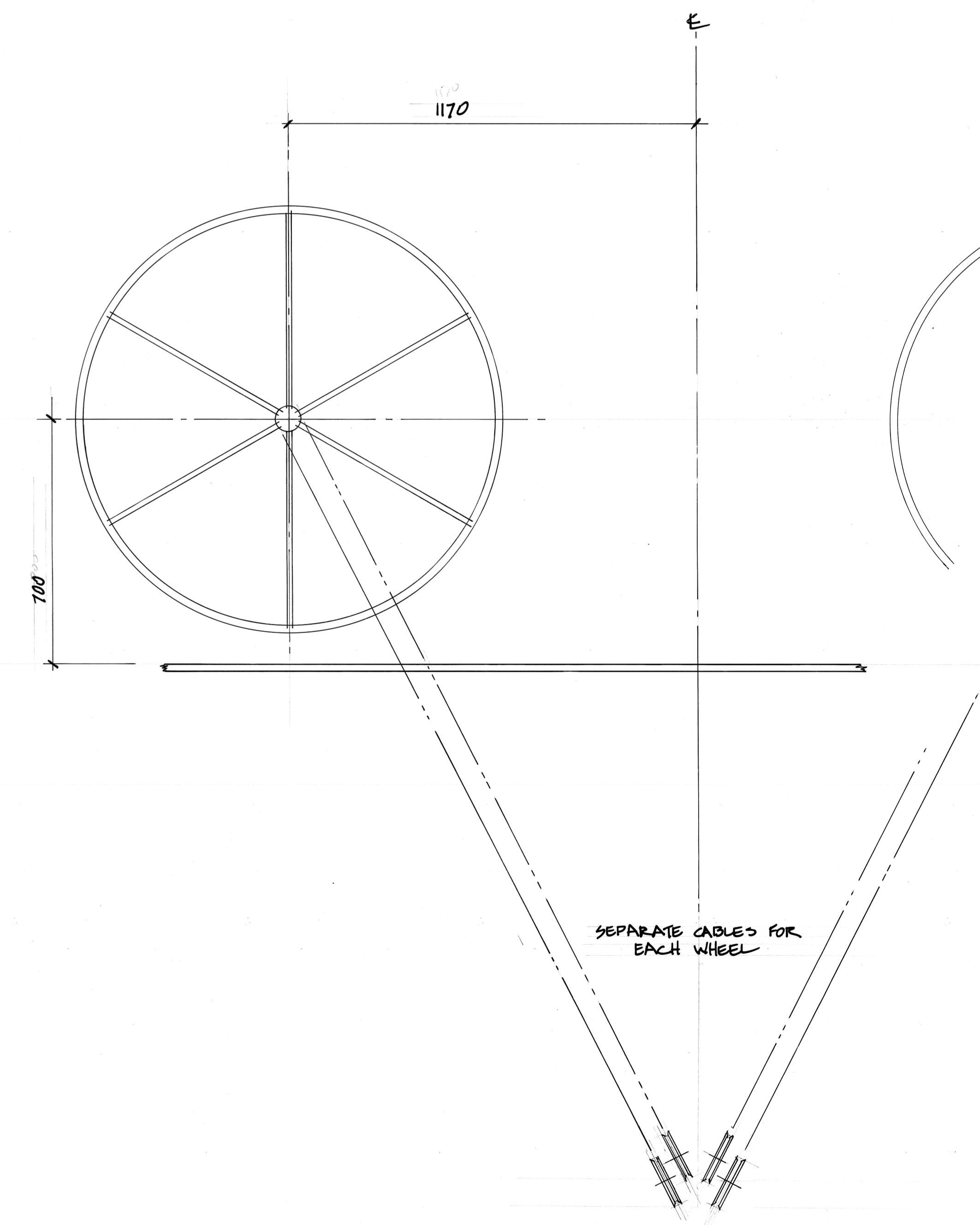
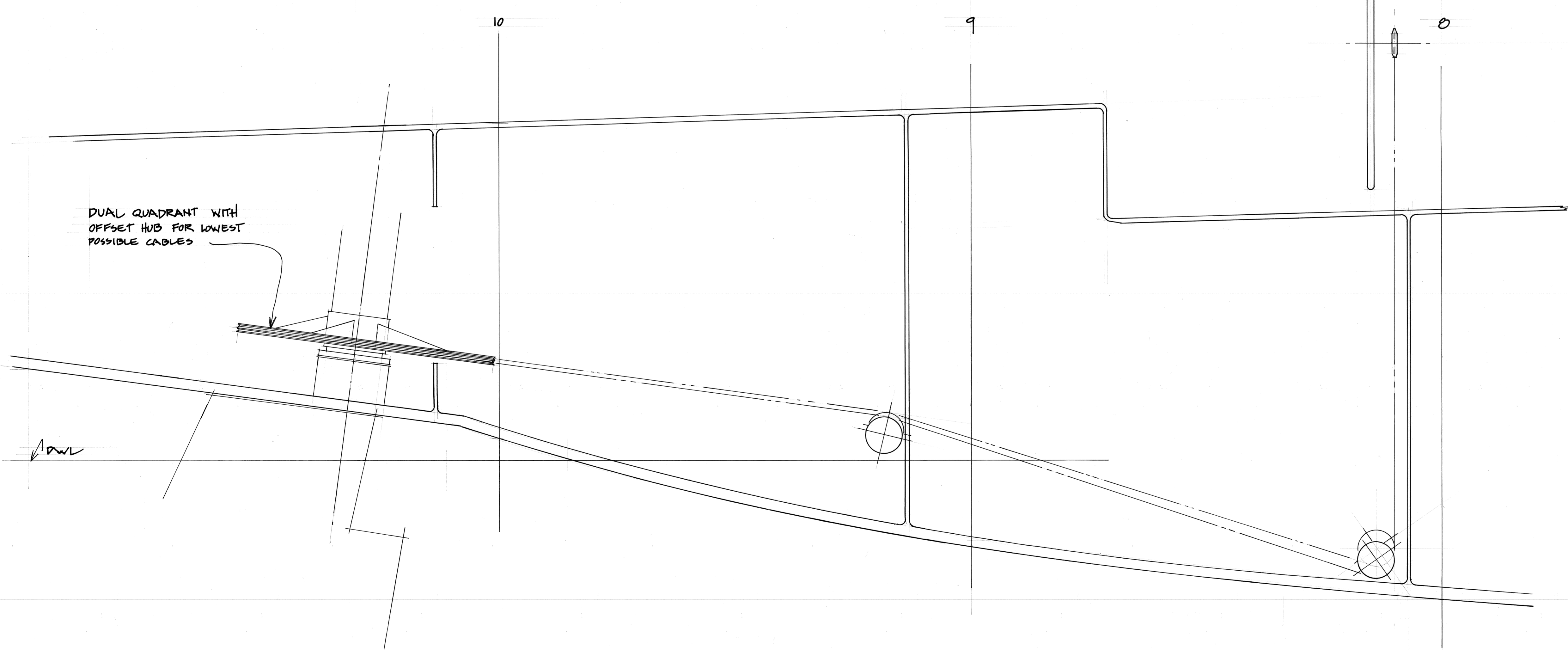

REVISIONS  <small>THE BUILDER MUST CHECK DIMENSIONS AND CONTENT GIVEN ON THE DRAWING AND ADVISE THE DESIGNER OF ANY DISCREPANCIES BEFORE COMMENCING CONSTRUCTION. THIS DRAWING MUST NOT BE REPRODUCED OR USED FOR ANY PURPOSE OTHER THAN IN CONNECTION WITH THE BOAT OR DESIGN FOR WHICH IT WAS DRAWN WITHOUT THE DESIGNER'S WRITTEN CONSENT. THE COST OF THESE PLANS INCLUDES FEES FOR ONE BOAT ONLY FOR USE OF THESE PLANS. ADDITIONAL BOATS SHALL BE BUILT FROM THESE PLANS WITHOUT THE DESIGNER'S WRITTEN CONSENT AND PAYMENT OF FEES.</small>	<b>BRUCE FARR® AND ASSOC., INC.</b> P.O. BOX 3457, ANNAPOLIS, MD. 21403, U.S.A.	
	<b>MAXI YACHT</b> FOR - S.O.R.C. - PIERRE FEHLMANN	
	SCALE 1:10	DESIGN NO. 103
	TITLE STEERING SCHEMATIC	COPYRIGHT 27 APRIL, 1980 © BRUCE FARR® & ASSOC., INC. DRAWING NO. 15